

APPLICATION

A pilot-operated pressure relief valve SVP-P is a pressure relief valve in which the major relieving device is combined with, and is controlled by, a self-actuated auxiliary pilot.

It's designed to be used wherever there is a need to exhaust the overpressure volume of gas.

Applications include gas production systems, compressor stations, gas transmission (pipelines) facilities, storage systems, distribution systems and in all types of processing plants.

DESIGN FEATURES

SVP-P soft seat pilot-operated safety relief valves operate on the principle of unequal areas exposed to the same pressure. When the relief valve is closed, system pressure pushes upwards against the piston seat seal on an area equal to the inside diameter of the seat. Simultaneously, the same system pressure passes through the pilot, exerting a downward force on the piston acting on an area approximately 50% greater than the inside diameter of the seat. The resulting differential force holds the valve tightly closed. As the system pressure rises, the force against the piston seal increases.

When the system pressure reaches the relief valve discharge set pressure, the pilot cuts off system pressure and opens the top of the piston to vent pressure, the pilot valve discharge the chamber of the main valve (releasing pressure) and the main valve opens completely ($h=D$)

When the predetermined blowdown pressure is reached (93-97,5% of set pressure), the pilot shuts off the exhaust and re-opens the flow of system pressure to the top of the piston with higher pressure value, which effectively close the relief valve.

Therefore, the basic advantage of the pilot operated safety relief valve is that it, when coming closer to the pre-set discharge pressure, force increases and seat-tightness is better. With the conventional valve it is the opposite – when coming close to the opening pressure, valve starts gradually to release. This valve can be operated in applications with a back pressure ratio of up to 70% which makes it ideal for a non stable systems.

Flange dimensions can be modified on request to fit most existing installations. This permits SVP-P pilot-operated safety relief valve to be used as replacements for older spring-loaded valves which may not conform to new safety standards.

PILOT

This pilot has a fixed blowdown for controlling relief valve opening and closing pressure set points. The opening set pressure is determined by the force of a control spring, which holds the relief control section of the valve closed. When system pressure acting on the relief control valve seat area equals the spring force, the relief line opens, and the blowdown control section closes, blocking system pressure from passing into the chamber above the main valve piston. As the relief line opens, the pressure underneath the control seat is exposed to a larger pressure area which immediately makes the control pilot to quickly reduce pressure in the piston area.

This pressure reduction causes the main valve piston to lift, relieving system pressure. After the system pressure is reduced to a point determined by the control spring, the relief control valve closes, and the open blowdown line valve allows system pressure to re-enter the piston area, forcing the main piston down to a closed valve position.

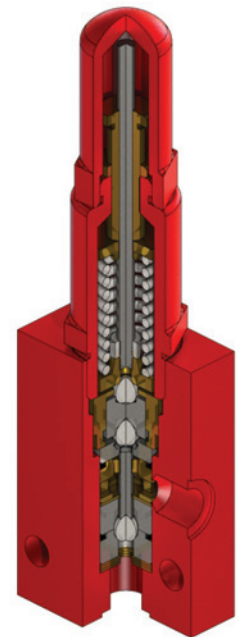

DN	50 - 150
PN	16 - 64
ANSI	150 - 600lb
P _{max}	50 bar
t	-20°C / +90°C
acceptable media	natural gas, LPG, air, non-aggressive gasses
connections	ANSI B 16.5, EN1092, DIN2633, DIN2634

Pilot-operated safety relief valve type SVP-P



CODE	DN1	DN2	L (mm)	L1 (mm)	H (mm)	set pressure (bar)	WEIGHT(kg)
031001	50 (2")	80 (3")	150	202	308	16 - 50	22
031002	80 (3")	100 (4")	173	222	318		33
031003	100 (4")	150 (6")	206	268	350		55

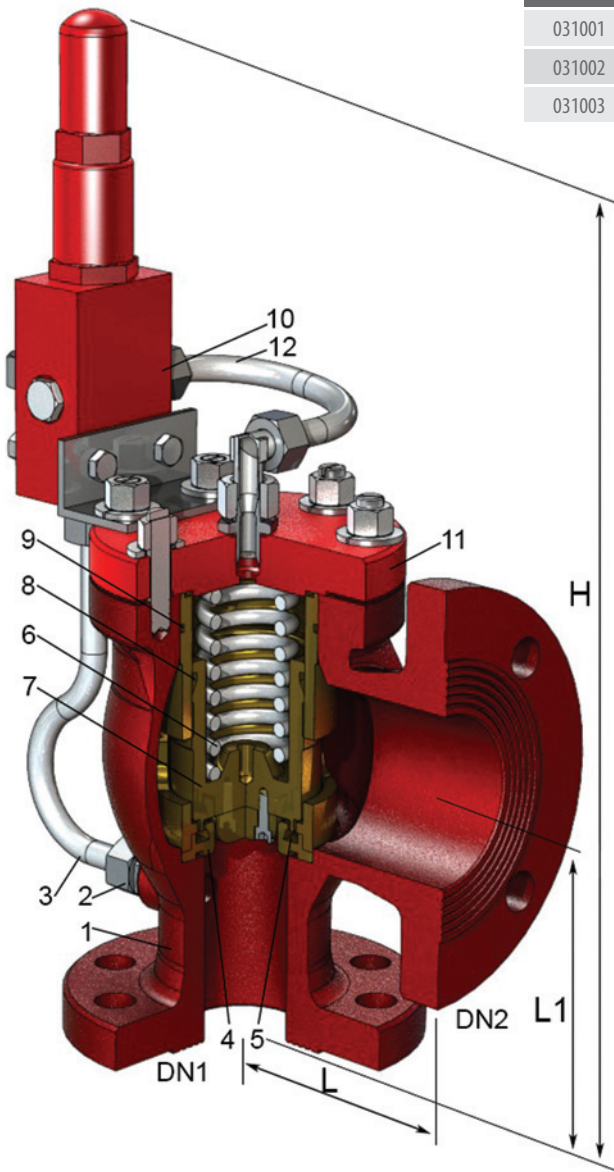

Pos.	Part name	Material	Standard
1	Housing	WCB	
2	Nozzle	P265GH	EN10273
3	Pipe	P235GH	EN10216-2
4	Seat	CC333G	EN1982
5	Gasket	NBR	
6	Spring	1.4301	EN10270-3
7	Piston	CC333G	EN1982
8	Seal	PTFE	
9	"O" ring	NBR	
10	Pilot		SPO
11	Lid	P265GH	EN10028-2
12	Pipe	P235GH	EN10216-2

ON REQUEST:

- In addition to the various API orifice sizes, on request it can be delivered with non-standard API orifice sizes for maximum flow capacity.
- Flange dimensions can be modified on request to fit most existing installations. This permits SVP-P pilot-operated safety relief valve to be used as replacements.

APPLIED STANDARDS, CODES & DIRECTIVES

API 526 "Flanged steel pressure relief valves"

EN ISO 4126-4 "Safety devices for protection against excessive pressure - Pilot operated safety valves"

94/9 EC (ATEX) "Equipment and protective systems intended for use in potentially explosive atmospheres"

